

Features

- 0.15 or 0.22NA 105µm core multimode fiber pigtail
- Uncooled
- Laser welded and epoxy free
- Hermetically sealed
- Built in thermistor
- Telcordia GR-468 Core / MIL-Std 883 compliant

Applications

- Fiber lasers
- Yb laser pumping
- Marking
- Material processing
- Defense

General Description

The EM4 high power laser has a fiber coupled output power of typical 6W. The module is ideal for use in a variety of applications where brightness is essential with a reliable and robust packaging. The module is a hermetically sealed 14 pin butterfly metal ceramic package and contains a thermistor and monitor detector. The module is pigtailed using a step index fiber with a 0.15 or 0.22 numerical aperture, 105 micron core diameter.

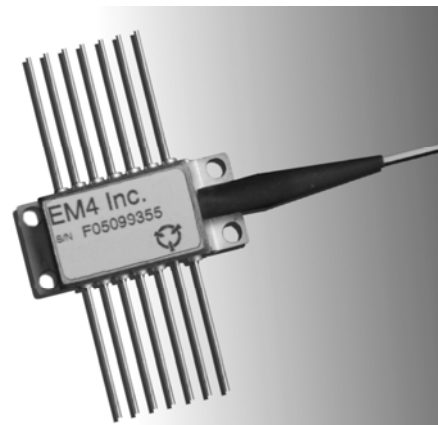

Ordering Information

Part	λ_c [nm]	Fiber NA
EM328	975	0.15
EM329	975	0.22

Absolute Maximum Ratings

Stresses beyond those listed under "Absolute Maximum Ratings" may cause permanent damage to the device. These are stress ratings only and operation of the device at these or conditions beyond these are not implied. Exposure to absolute maximum ratings for extended periods of time may affect device reliability.

Parameter	Sym	Condition	Min	Max	Unit
Storage Temperature	T_{STG}		-40	85	°C
Operating Case Temperature	T_{OP}		-20	70	°C
Laser Forward Current	I_F			11	A
Laser Reverse Voltage	V_R			2	V
PD Forward Current	I_{PD}			20	mA
PD Reverse Voltage	V_{PD}			20	V
Thermistor Current				2	mA
Thermistor Voltage				5	V
Fiber Pull Force				5	N
Fiber Bend Radius			35		mm
Lead Soldering Time				10	s
Lead Soldering temperature				250	°C
ESD		HBM		500	V

For pricing and delivery information, please contact EM4 inc. direct at +1 781 275 75 01, sales@em4inc.com or any of the representatives listed at www.em4inc.com.

The information published in this datasheet is believed to be accurate and reliable. EM4, Inc. reserves the right to change without notice including but not limited to the design, specification, form, fit or function relating to the product herein. ©2004 EM4, Inc. All rights reserved.



6W 975nm 14 Pin Multimode Pump Laser

Optical And Electrical Characteristics

T_C=25°C unless otherwise specified.

Parameter	Sym	Condition	Min	Typ.	Max	Unit
Center Wavelength	λ_C	I=I _{OP} -1	965	975	985	
Operating Current	I _{OP}	P=P _{OP}			8	A
Operating Voltage	V _{OP}	I=I _{OP}			2.2	V
Output Power	P _{OP}		6			W
Threshold Current	I _{TH}			0.4	0.6	A
Wavelength Drift vs. T _C	$\delta\lambda/\delta T_C$			0.3		nm/°C
Spectral Width	$\Delta\lambda$	17dB down from peak		6		nm
Operating Case Temperature	T _C		0		45	°C
Thermistor Resistance	R _{TH}	T=25°C	9500	10000	10500	Ω
Thermistor β coefficient	β	0 / 50°C		3892		

Fiber Specification

Parameter	Sym	Condition	Min	Typ.	Max	Unit
Fiber Type			Step Index			
Jacket Material			PVDF			
Numerical Aperture		EM328		0.15	0.17	
		EM329		0.22	0.24	
Core Diameter			102	105	108	μm
Cladding Diameter			123	125	128	μm
Buffer Diameter			235	250	265	μm
Jacket Diameter				900		μm
Jacket Length From End Of Boot			75		95	mm
Pigtail Length			1			m

For pricing and delivery information, please contact EM4 inc. direct at +1 781 275 75 01, sales@em4inc.com or any of the representatives listed at www.em4inc.com.

The information published in this datasheet is believed to be accurate and reliable. EM4, Inc. reserves the right to change without notice including but not limited to the design, specification, form, fit or function relating to the product herein. ©2004 EM4, Inc. All rights reserved.

Typical Operating Characteristics

T_c=25°C

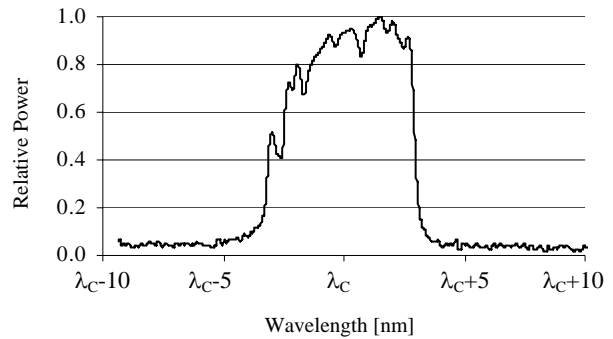
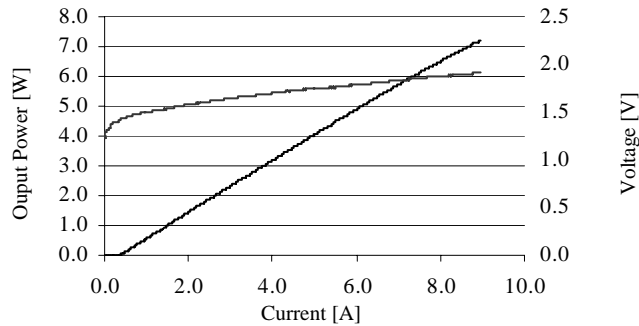

Mechanical Drawing

All units in mm

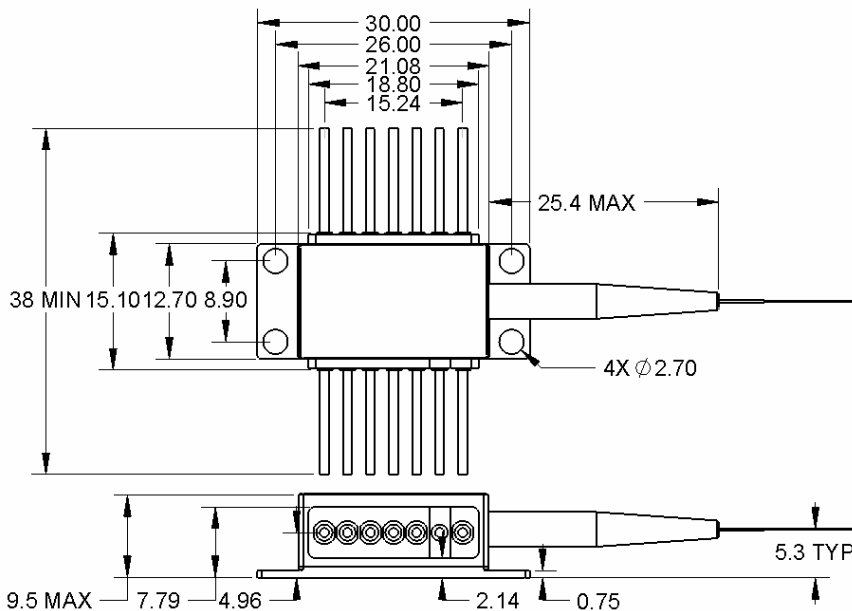

Pinning

Pin	Description
1	NC
2	Thermistor
3	Monitor Anode
4	Monitor Cathode
5	Thermistor
6	Monitor Cathode
7	Monitor Anode
8	NC
9	Laser Cathode
10	Laser Anode
11	Laser Cathode
12	NC
13	Case GND
14	NC



The component complies with all applicable portions of 21 CFR 1040.10, 21 CFR 1010.2 and 21 CFR 1010.3. Since this is a component, it does not comply with all of the requirements contained in 21 CFR 1040.10 and 21 CFR 1040.11 for complete laser products.

For pricing and delivery information, please contact EM4 inc. direct at +1 781 275 75 01, sales@em4inc.com or any of the representatives listed at www.em4inc.com.

The information published in this datasheet is believed to be accurate and reliable. EM4, Inc. reserves the right to change without notice including but not limited to the design, specification, form, fit or function relating to the product herein. ©2004 EM4, Inc. All rights reserved.